

NT1-A

STUDIO CONDENSER MICROPHONE

The RØDE NT1-A 1" cardioid condenser microphone has become an industry standard; delivering the warmth, extended dynamic range, clarity and high SPL capability typically only featured on some of the world's most expensive microphones.

- Large 1" (25mm) capsule with gold plated diaphragm
- Cardioid polar pattern
- Self noise of only 5dB (A)
- Ultra low noise, transformerless surface mount circuitry
- Wide dynamic range
- Gold plated output contacts
- True condenser (externally biased)
- Internal capsule shock mounting



SHOCK MOUNT
& DETACHABLE
POP FILTER



48V PHANTOM
POWER



CABLES
INCLUDED



ACOUSTIC & ELECTRICAL SPECIFICATIONS

Acoustic Principle:	Pressure gradient
Active Electronics:	JFET impedance converter with bipolar output buffer
Capsule:	1.00"
Polar Pattern:	Cardioid
Address Type:	Side
Frequency Range:	20 Hz-20 kHz
Output Impedance:	100Ω
Maximum SPL:	137dB SPL
Sensitivity:	-32 dB re 1 Volt/Pascal (25 mV @ 94 dB SPL) +/- 2 dB @ 1kHz
Equivalent Noise Level:	5dBA (A-weighted)
Power Requirements:	P24 or P48
Output Connection:	3 pin XLR, balanced output between Pin 2 (+), Pin 3 (-) and Pin 1 (ground)
Maximum Output Level:	13.7mV (@ 1kHz, 1% THD into 1KΩ load)



RØDE

MECHANICAL SPECIFICATIONS

Weight (grams):	326
Dimensions (millimetres):	Height: 190 Width: 50 Depth: 50
Included Accessories:	1 x SM6 1 x XLR Cable

WHATS IN THE BOX



NT1-A



SM6



XLR Cable

DIMENSIONS

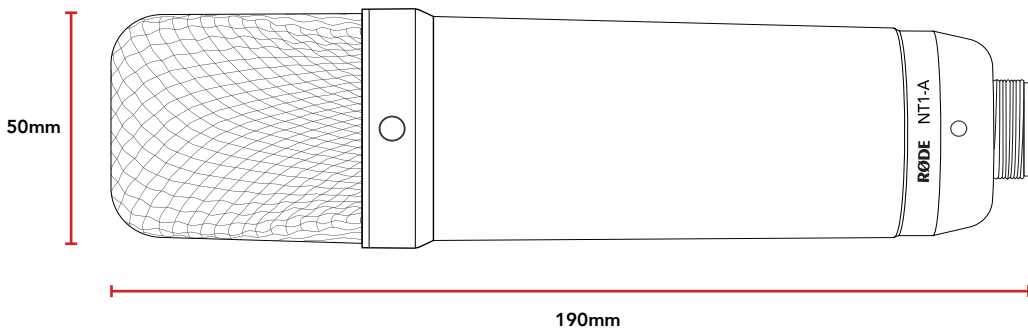

POLAR PATTERN

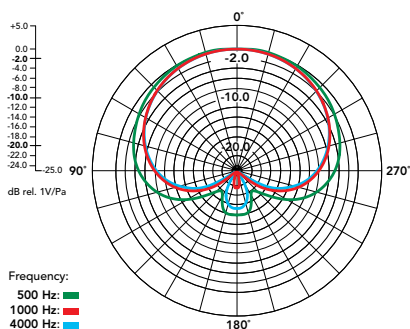

FREQUENCY RESPONSE

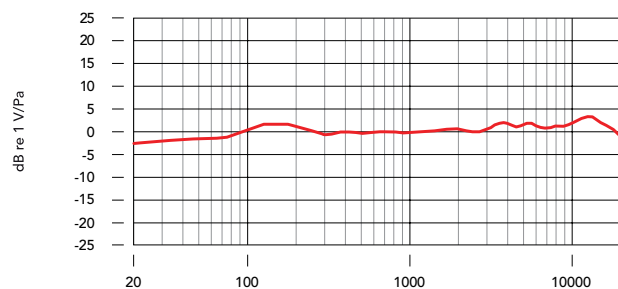

RØDE