

VIDEOMICPRO

ON-CAMERA SHOTGUN MICROPHONE

The RØDE VideoMic Pro is a true shotgun microphone designed for use with camcorders, DSLR cameras and portable audio recorders as a source of primary and reference audio. At the heart of the VideoMic Pro is an all-new 1/2" condenser capsule that provides broadcast-quality audio via a 3.5mm minijack connector (outputting the mono signal to both left and right channels) with an incredibly low self-noise of just 14dB. A super-cardioid polar pattern ensures that surrounding audio is minimised, and your recording is focused on the subject in front of the camera.

- Broadcast recording quality condenser microphone
- Compact form factor (150mm/6" length)
- Ultra lightweight (85g/3oz)
- 9V battery powered - over 70 hours use (alkaline)
- Switchable high-pass filter (flat or 80Hz)
- Three position level control (-10dB, 0, +20dB)
- Camera shoe mount with 3/8" thread for easy boompole mounting



INTEGRATED RYCOTE[®]
LYRE[®] SHOCK MOUNT



OVER 70 HOURS
BATTERY LIFE



+20dB
LEVEL
BOOST



ACOUSTIC & ELECTRICAL SPECIFICATIONS

Acoustic Principle:	Line Gradient
Directional Pattern:	Supercardioid
Frequency Response:	40Hz ~ 20,000Hz (selectable HPF@80Hz)
Sensitivity:	-32dB (25mV/Pa) +/- 2dB re 1V/Pa @1kHz
Output Impedance:	200Ω
Equivalent Noise:	14dB SPL (A - weighted per IEC651)
Maximum Output:	+6.9dBu (@ 1% THD into 1kΩ)
Dynamic Range:	120dB (per IEC651)
Maximum SPL:	134dB SPL
Signal-to-Noise Ratio:	80dB
Power Req:	9V alkaline battery (Current 7.8mA)
Dimensions (millimetres):	100 (height) x 75 (width) x 170 (depth)
Output Connection:	3.5mm stereo mini-jack (dual mono)
Net Weight (grams):	85



RØDE

WHAT'S IN THE BOX



VideoMic PRO

DIMENSIONS

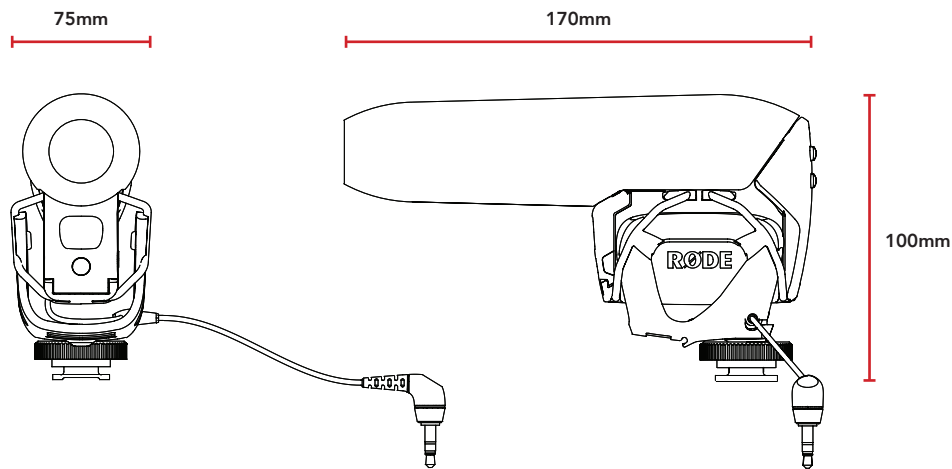

POLAR PATTERN

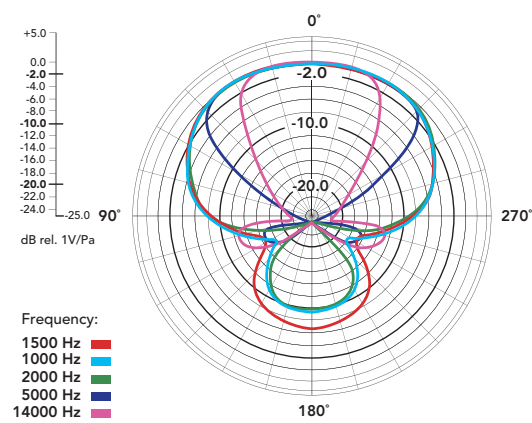

FREQUENCY RESPONSE

